



Nevada Site Specific Advisory Board (NSSAB)

Full Board Meeting Molasky Corporate Center Las Vegas, Nevada

4:00 p.m. – November 8, 2023

- Members Present:** Erik Anderson, Joycelyn Austin-Mabe, John Cole, Gary Elgort, Anthony Graham (Chair), Mark Hilton (Vice-Chair), Bruce Jabbour, Dan Peterson, Janice Six, Kevin Trainor, Favil West, Eddie Williams
- Members Absent:** Lisa Blandi, William Dolan
- Liaisons Present:** Christine Andres (State of Nevada Division of Environmental Protection [NDEP]), Andrew Bennett (Clark County), Frank Bonesteel (Nye County Emergency Management [NCEM]), Frank Carbone (Nye County Commission), Delon Winsor (Esmeralda County Commission)
- Liaisons Absent:** Richard Arnold (Consolidated Group of Tribes and Organizations [CGTO]), Varlin Higbee (Lincoln County Commission), John Klenke (Nye County Natural Resources and Federal Facilities Office [NRFFO]), Bill Wolf (White Pine County Commission)
- U.S. Department of Energy (DOE):** **Environmental Management (EM) Nevada Program:** Robert Boehlecke (Deputy Designated Federal Officer [DDFO]), Jhon Carilli, Tiffany Gamero, John Myers, Jackie Petrello
National Nuclear Security Administration/Nevada Field Office (NNSA/NFO): Dr. David Bowman, Kathryn Gladden
DOE Office of Legacy Management (LM): Meghan Hurt
U.S. Government Accountability Office (GAO): Madeline Kasik
- Government Contractors:** **Navarro Research and Engineering, Inc. (Navarro):** Irene Farnham, Grant Johnson, Glenn Puit, Ken Rehfeldt, Barbara Ulmer, John Wrapp
Desert Research Institute (DRI): Chuck Russell
U.S. Geological Survey (USGS): Wayne Belcher, Jeff Sanders

Open Meeting

Chair Anthony Graham welcomed everyone to the meeting and thanked both those joining virtually and in-person. He stressed the importance of the commitment made as an NSSAB member to attend the meetings on time and participating in events planned for the Board, such as tours of the Nevada National Security Sites (NNSS). Member Kevin Trainor moved to approve the draft agenda. The motion was seconded and passed unanimously.

Public Comment

There was no public comment:

Liaison Updates

Clark County (*Andrew Bennett*)

Liaison Andrew Bennett introduced himself as the Director of Traffic Safety for Clark County. He thanked the EM Nevada Program and NNSA/NFO for coordinating a briefing on the transportation of radioactive waste to the NNSS. In the upcoming months, Liaison Bennett noted that several large events will be held in Clark County, including the Formula 1 race, New Year's Eve, and the Super Bowl. On behalf of the Clark County Manager and the Board of County Commissioners, correspondence was provided to the EM Nevada Program to consider blackout dates for the transportation of radioactive waste during any event that meets the Homeland Security recognized level 2 and above. The Super Bowl is classified as a level 1 and New Year's Eve is a level 2. Liaison Bennett concluded that the county's interest continues to track both state and county projects that could have an impact to the safe transportation of low-level waste (LLW) by continuing to work with state partners, such as the State of Nevada Department of Transportation.

Nye County Commission (*Frank Carbone*)

Liaison Frank Carbone thanked John Daniels, NNSA/NFO Federal Public Affairs Officer, for conducting a tour for Nye County officials to gain a better understanding of past and current activities at the NNSS.

NDEP (*Christine Andres*)

Liaison Christine Andres reported that she will be attending the DOE EM Intergovernmental Meeting next week in Minneapolis, MN. During this week, five DOE-supported intergovernmental groups will meet that have different focuses. As a result of mischaracterized waste shipped to the NNSS from a generator in northeast Tennessee, Liaison Andres updated that DOE and NDEP entered into a Settlement Agreement. After four years of monitoring, NDEP will be issuing a final letter to close out the Settlement Agreement as the agreed-upon waste management improvements have been put into place by the Department.

Esmeralda County Commission (*Delon Winsor*)

Liaison Delon Winsor commented that the county is working with Greenlink Nevada, a renewable energy and electrical infrastructure initiative, that will be completed in 2028. The gold and lithium mines are moving forward and are forecasted to start construction phases next year.

NNSA/NFO Update (*Dr. David Bowman, Manager and Kathryn Gladden, EM Program Liaison for NNSA/NFO*)

Dr. David Bowman reported that NNSA/NFO's management and operating contractor, Mission Support and Test Services, LLC (MSTS), is in the process of reworking the labor agreements with the approximately 1,000 craft workers in the Southern Nevada Trades Alliance that work on the NNSS. MSTS has successfully completed negotiations with 18 of the 22 separate unions, however the United Association of Plumbers, Pipefitters and Service Technicians Local 525 union is striking, and the other trades alliance members have walked out in sympathy. It is hopeful that an agreement will be reached in order to move forward. Dr. Bowman updated that the NNSS is one of five DOE sites selected to potentially host commercial industries that develop carbon-free solar energy. A request for information will be submitted to interested parties that will be followed by an industry day in mid-February 2024. The identified area is east of Mercury Highway on the far southeastern part of the NNSS. The NSSAB will continue to receive updates at future NSSAB meetings on this initiative.

Kathryn Gladden updated that preparation continues on a Supplemental Analysis (SA) to assess the potential environmental impacts from continued operations on the NNSS. The SA will document changes that occurred since the publication of the Site-Wide Environmental Impact Statement in 2013 and the associated Record of Decision. The document will also address impacts five years into the future. The SA documentation is in the process of being finalized and will include an appendix that addresses comments provided by NDEP, the Tribes, Nye County, and Clark County. An anticipated Record of Decision is anticipated to be published in February 2024.

U.S. DOE Update (*Robert Boehlecke, DOE*)

DDFO Robert Boehlecke reported on the following DOE EM Nevada Program updates:

- **Industrial Sites Activity:** The EM Nevada Program recently completed scheduled demolition at the Test Cell C (TCC) Facility at the NNSS. Crews safely carried out the demolition of four buildings listed in the EM calendar year 2023 Mission and Priorities. Industrial Sites continues to prepare for future demolition of the Engine Maintenance, Assembly and Disassembly (EMAD) Facility and has also completed removal, packaging, and disposal of asbestos-containing insulation, hazardous materials, and equipment from the EMAD trainshed. Crews have completed the characterization, packaging, and disposal of waste from an intermodal at TCC and four intermodals at EMAD. The EM Nevada Program looks forward to making continued progress on this work in the coming months.
- **Underground Test Area (UGTA):** Crews are currently conducting sampling in Pahute Mesa and preparing for upcoming drilling planned for next year.
- **Clark County Office of Traffic Safety:** In October 2023, a briefing was conducted for the Clark County Office of Traffic Safety by the EM Nevada Program and the NNSA/NFO. Topics included waste transportation basics along with an emergency management overview with details on the Haztrak program, NNSS Fire and Rescue, and the Radiological Assistance Program. The EM Nevada Program will be working with Liaison Bennett, the Nevada State Police, and the Clark County team in the future on these important issues.

- **NSSAB:** The EM Nevada Program hosted an NNSS tour for NSSAB members and liaisons in October 2023. This included stops at the Area 5 Radioactive Waste Management Complex (RWMC), a well drill site in Pahute Mesa, and a progress status update for TCC and EMAD Facilities. NSSAB recruitment for new members has kicked off with attendance at a Latin Chamber of Commerce networking event, vendor booth during Beatty Days, presentation during an Amargosa Valley Town Board meeting, with more presentations being planned in both Nye County and Las Vegas. A social media campaign will soon be initiated for the recruitment drive. NSSAB members and liaison are encouraged to recruit potential members to serve on this important Board.
- **STEM Saturdays:** The EM Nevada Program hosted a very successful presentation for a STEM Saturdays event in early November 2023 at The Atomic Museum. Navarro's UGTA hydrologist, Hugh Klein, met with school children from across Clark County and provided a primer on groundwater and how it moves through different mediums. Navarro's strategic communications team also carried out a series of scientific experiments. The children and parents then had the opportunity to tour the museum.
- **STEM Grants:** The EM Nevada Program's contractor, Navarro, received 26 applications for STEM grants. Judging recently took place and a public announcement of the winners will be released.
- **DOE EM Intergovernmental Meeting:** DDFO Boehlecke will be attending the 22nd annual DOE EM Intergovernmental Meeting next week in Minneapolis, MN, and also will be participating in a panel discussion. This meeting provides a forum for state, local, tribal, and federal officials to discuss priorities and strategies for managing and storing defense nuclear waste and for remediation of production sites.

FY 2023 Wrap Up and FY 2024 Planned Activities Briefings *(DOE Activity Leads)*

Long-Term Monitoring *(Tiffany Gamero, DOE)*

- **Background**
 - Long-Term Monitoring sites include Corrective Action Sites that are now closed under the Federal Facility Agreement and Consent Order and require some form of reporting, maintenance, monitoring, or inspections
 - Closed Soils Sites
 - Closed Industrial Sites
 - Closed Underground Test Area (UGTA) Sites
- **Long-Term Monitoring FY 2023 Wrap Up**
 - Planned: Submit Resource Conservation Recovery Act (RCRA), Non-RCRA, Post-Closure Monitoring Letter Report, and UGTA Calendar Year (CY) 2022 Post-Closure Monitoring Letter Report to NDEP
 - Status: No significant concerns identified during post-closure inspections
 - RCRA Post-Closure Report – submitted May 2023
 - Non-RCRA Post-Closure Report – submitted June 2023
 - Final Post-Closure Monitoring Letter Report – submitted May 2023
 - UGTA CY 2022 Post-Closure Monitoring Letter Report – submitted June 2023
 - Planned: Conduct quarterly, biannual, and annual monitoring at closed sites
 - Status: All required monitoring was conducted in FY 2023

- Planned: Continue path forward for Corrective Action Unit (CAU) 111 revegetation
 - Status: Conducted seeding on North-North Cover of 92-Acre Area in February 2023
- Planned: Conduct UGTA annual water level monitoring
 - Status: Completed; results consistent with modeling; no concerns identified
- Planned: Conduct post-closure monitoring well inspections on wells in the sampling and groundwater level network
 - Status: Completed
- **Long-Term Monitoring FY 2023 Additional Activities**
 - CAU 577 Revegetation
 - Status: Conducted seeding on cover of Cell 21 in February 2023
- **Long-Term Monitoring FY 2024 Planned Activities**
 - Submit RCRA, Non-RCRA, Post-Closure Monitoring Letter Report, and UGTA CY 2023 Post-Closure Monitoring Letter Reports to NDEP
 - Conduct quarterly, biannual, and annual monitoring at closed sites
 - Continue path forward for CAU 111 and 577 revegetation
 - Conduct UGTA annual water level monitoring
 - Conduct post-closure monitoring well inspections on wells in the sampling and groundwater level network

In response to a Board question, the following clarification was provided:

- It is too soon to measure any changes in groundwater levels in wells on the NNSS due to the recent heavy rains.

Industrial Sites (*Jackie Petrello, DOE*)

- **Background**
 - Portions of the facilities and land at the NNSS and Nevada Test and Training Range were used in direct support of nuclear testing
 - Facilities included such things as gas stations, motor pools, maintenance shops, and research buildings
 - Activities resulted in releases of contaminants to the environment
 - EM Nevada Program established the Industrial Sites activity to remediate identified contaminated sites
 - Industrial Sites have included facilities, leach fields, sumps, disposal wells, tanks, contaminated waste piles, ordnance sites, etc.
 - Contaminants of concern may include hazardous chemicals, unexploded ordnance, and radionuclides
 - Closure completed at 99% of FFACO Corrective Action Sites; 1955 of 1975 total Industrial Sites have been completed
- **Industrial Sites FY 2023 Wrap Up**
 - Planned: Continue FFACO closure activities at EMAD and TCC Facilities
 - Status:
 - Continued closure activities at both EMAD and TCC
 - Draft Closure Report for TCC is in development
 - EMAD
 - Completed asbestos abatement on basement through floor 3

- Completed waste disposal activities in the Trainshed
- TCC
 - Completed demolition of the following buildings:
 - Equipment Building
 - Cryogenic Evaluation Laboratory
 - Electrical Pump Room
 - Motor Drive Building
 - Electrical Substation
 - Borated Water System
 - Planned: Continue cultural resource activities in conjunction with Nevada State Historic Preservation Office (SHPO)
 - Status: Continued cultural resource activities in conjunction with the SHPO
 - Planned: Submit Addendum 2 to the Closure Report for CAU 577 Area 5 Chromium Containing Waste Disposal Cells to NDEP – September 2023
 - Status: Addendum 2 was submitted to NDEP on September 28, 2023
- **Industrial Sites FY 2023 Additional Activities**
 - CAU 578 Miscellaneous Inactive Sites
 - Submitted the Streamlined Approach for Environmental Restoration (SAFER) Plan and received NDEP approval in the spring of 2023
 - Completed the field sampling and investigation
 - Closure Report is expected to be submitted to NDEP in the late fall of 2023
 - Continue cultural resource activities in conjunction with SHPO
 - Complete CAU 578 Closure Report – February 2024
 - EMAD and TCC
 - Continue FFACO closure activities
 - Demolition of the TCC Spherical Water Tank, Water Tower and Dewars 4 and 5
 - Demolition of the Trainshed and completion of EMAD roof-top asbestos abatement
 - Demolition of the EMAD Water Tower

In response to a Board question, the following clarification was provided:

- The EM Nevada Program would donate the EMAD windows for reuse purposes, although there has not been a need found in the DOE Complex. The Program will work with NDEP in a decision-making process for disposal of the windows if a reuse is not found.

Underground Test Area (Groundwater) *(John Myers, DOE)*

- **Background**
 - 828 underground nuclear tests conducted at the NNSS from 1951 to 1992
 - Underground tests conducted at depths ranging from approximately 90 to 4,800 feet below the ground surface
 - One-third of these tests occurred near or below the water table
 - Radioactive contamination from testing not detected above the Safe Drinking Water Act maximum contaminant level (MCL) in groundwater beyond federally controlled land

- **UGTA CAUs**
 - There are five CAUs determined by location and geologic conditions that make up the UGTA Activity on the NNSS:
 - Frenchman Flat – 10 sites (CAU 98) – **COMPLETE** (in closure/long-term monitoring)
 - Rainier Mesa/Shoshone Mountain – 66 sites (CAU 99) – **COMPLETE** (in closure/long-term monitoring)
 - Yucca Flat/Climax Mine – 720 sites (CAU 97) – **COMPLETE** (in closure/long-term monitoring)
 - Central and Western Pahute Mesa – 82 sites (CAU 101/102) (in Corrective Action Decision Document/Corrective Action Plan stage)
- **UGTA FY 2023 Wrap Up**
 - Planned: Submit External Peer Review Report to NDEP – April 2023
 - Status: Completed 3/27/2023
 - Planned: Begin Corrective Action Decision Document/Corrective Action Plan activities and reporting – May 2023
 - Status: Began 5/19/2023
 - Planned: Collect groundwater samples from 9 locations – September 2023
 - Status: Completed 11 locations 9/26/2023
 - Planned: Continue funding and support for Nye County Tritium Sampling and Monitoring Program (TSaMP) and internal peer review membership
 - Status: No detectable tritium in TSaMP samples to date
- **UGTA FY 2023 Additional Activities**
 - Submitted Calendar Year 2022 Annual Sampling Letter Report to NDEP on 6/28/2023
- **UGTA FY 2024 Planned Activities**
 - Pahute Mesa
 - Submit Corrective Action Decision Document/Corrective Action Plan to NDEP (10/30/2023)
 - Drill groundwater well ER-20-13 (9/30/2024)
 - Drill (deepen) groundwater well ER-20-1 (9/30/2024)
 - Continue funding and support for Nye County TSaMP and internal peer review membership

In response to Board questions, the following clarifications were provided:

- Well sites ER-20-1 and ER-20-13 are a little over two miles apart as the crow flies.
- The plants and the seeds from these plants that grow in the higher elevations of Pahute Mesa are not well-suited for revegetation efforts on landfill covers located at lower elevations of the NNSS.
- The two wells planned for Pahute Mesa will be drilled deeper in order to reach aquifers that UGTA has no sampling data.

Waste Management (*Jhon Carilli, DOE*)

- **Background**
 - Cold War-related activities and nuclear research generated waste necessitating a safe disposal option
 - DOE is responsible for consolidating and disposing waste generated by clean-up activities and ongoing national security and science missions

- DOE Office of EM Nevada Program oversees acceptance of waste for safe and secure disposal at the NNSS
 - The NNSS was chosen due to its isolated location, security, and arid climate
 - Waste disposal ongoing since 1961
 - Independent oversight conducted, in part, by State of Nevada regulators
- **Waste Management FY 2023 Wrap Up**
 - Planned: Safely dispose up to 750,000 cubic feet (ft³) of waste at the NNSS in FY 2023
 - Status: As of September 30, 2023, the NNSS safely disposed 595,656 ft³ of waste
 - Planned: Submit annual Performance Assessment Summary Report to the LLW Federal Review Group
 - Status: Submitted in March 2023; continues to meet Performance Objectives included in DOE Order 435.1 *Radioactive Waste Management*
 - Planned: Submit Radioactive Waste Acceptance Program (RWAP) Annual Report
 - Status: Submitted to and accepted by NDEP in January 2023
 - Planned: RWAP facility evaluations
 - Status: Conducted 35 facility evaluations
 - NDEP participated in 23 of these facility evaluations
 - Status: Conducted the following Verifications
 - 9 mixed LLW
 - 2 onsite LLW
 - 25 LLW real-time radiography (RTR)
 - 28 waste profiles
 - Planned: Continue funding and support for the Emergency Preparedness Working Group (EPWG) grant
 - Status: Provided over \$16 million in funding through the State of Nevada Division of Emergency Management to Clark, Elko, Esmeralda, Lincoln, Nye, and White Pine counties since FY 2000
 - EM Nevada Program funds the grant based on \$.50 per cubic foot of classified, LLW and mixed LLW disposed at the NNSS
 - Funding provided in accordance with approved grant application and oversight of funding use
 - Priorities for grant funding include consideration for the needs of a county and the resource base available in that county
 - Planned: Operationally close and construct disposal cells, as needed
 - Status:
 - Cell 21 operationally closed
 - Cell 29 construction almost complete
 - Cell 30 under construction
- **Waste Management FY 2024 Planned Activities**
 - Safely disposal up to 750,000 ft³ of waste at the NNSS
 - Submit annual Performance Assessment Summary Report to the LLW Federal Review Group
 - Conduct RWAP facility evaluations
 - Continue funding and support for the EPWG grant
 - Operationally close and construct disposal cells, as needed
 - Install the new real-time radiography (RTR) portal unit

In response to Board questions, the following clarifications were provided:

- The new RTR portal unit will have the capability to scan radioactive waste on the truck as it drives through the turn-around area at the Area 5 RWMC.
- The typical depth of a waste cell is enough to cover two cargo containers with over eight feet of cover on the top or around 21 feet.

The Board thanked the presenters for the briefings and being available for questions.

Other NSSAB Business *(Anthony Graham, Chair)*

NSSAB Update on LLW Stakeholders Forum

Member Trainor shared items of interest from his attendance at the LLW Stakeholders Forum held on November 7, 2023, in Las Vegas. Chair Graham thanked him for attending the meeting and providing his report.

NSSAB Attendee at Waste Management Symposia

Chair Graham informed the NSSAB of an opportunity for a member to attend the annual Waste Management Symposia in Phoenix, AZ, from March 10-15, 2024. The member chosen will be responsible for providing an oral report at the April NSSAB meeting. Member Joycelyn Austin-Mabe volunteered to attend this year with Member Gary Elgort as the alternate.

NSSAB Recommendation on Future EM Site-Specific Advisory Board (SSAB) National Chairs' Meetings

Chair Graham updated the NSSAB that the fall EM SSAB National Chairs' Meeting was cancelled due to a potential government shutdown. He shared numerous concerns and a letter with the NSSAB that requests clarification on six key questions regarding the cancellation. Chair Graham also shared with the Board a draft recommendation addressed to DDFO Boehlecke and DFO Kelly Snyder that no NSSAB or EM SSAB National Chairs' Meetings be scheduled to begin later than the twentieth day of September or during the month of October in any federal fiscal year and that a back-up digital option be available in case unforeseen circumstances require cancellation of an in-person meeting.

DDFO Boehlecke offered additional information that the EM SSAB National Chairs' Meeting schedule is set months in advance based on availability of the host site and EM HQs senior management. The host site is planned on a schedule and set four years in advance, and it was Oak Ridge Site's turn in the rotation. The last-minute cancellation of the meeting was based on the best available information at the time and consistent with past practice when there is not a clear path forward for sufficient funding. There has been a commitment to host the meetings in-person to the greatest degree possible. Some host sites do not have the capability to host virtual meetings, which would require hiring an outside entity to provide this service.

Member Elgort made a motion that the draft recommendation letter and the letter of inquiry regarding future scheduling of NSSAB and EM SSAB National Chairs' Meetings be approved and submitted to DOE for its consideration and response. The motion was seconded and passed unanimously.

Updates to the Federal Facility Agreement and Consent Order – Work Plan Item #6 (Tiffany Gamero, DOE)

- **NSSAB – Work Plan Item #6**
 - From a community perspective, the NSSAB will provide a recommendation on improvements or enhancements to Appendix V, *Public Involvement* and the new Appendix VII, *Post-Closure Strategy*
 - NSSAB recommendation is due tonight
- **Overview**
 - FFACO updates presented during September 20, 2023, NSSAB meeting
 - Draft FFACO Appendices V and VII provided to NSSAB on October 24, 2023
 - Signatory representatives agree on proposed changes to FFACO
 - Signatory representatives will collaboratively address NSSAB recommendations on proposed changes to FFACO
- **Appendix V Public Involvement Plan**
 - Presents a broad public involvement strategy for providing information and actively seeking public input on FFACO-mandated activities
 - Reflects FFACO signatories' commitment to inform and, as appropriate, engage the public:
 - As investigations and corrective actions are planned
 - During the decision-making process to achieve closure of sites
 - Throughout post-closure monitoring
 - Proposed revision streamlines and updates tools available for engaging with the public (NSSAB, NNSS and Office of LM online resources, Public Reading Facilities, NNSS tours, fact sheets, annual reports)
- **Appendix VII Post-Closure Strategy**
 - Outlines regulatory approach for activities following completion of the Corrective Action Strategy (Appendix VI) for FFACO CAUs
 - Provides for fulfilling post-closure surveillance and monitoring requirements following CAU closure
 - Describes long-term stewardship transfer and implementation processes that require NDEP notification, input, and approval
 - Clarifies that DOE internal processes are not included
 - Implements consistent post-closure processes for subsurface (UGTA/Offsites) and surface monitoring (Industrial Sites/Soils/Offsites)
 - Presents tools (e.g., FFACO database, FFACO documents, meetings, Use Restriction forms) that identify post-closure monitoring and long-term stewardship requirements
- **Key Messages**
 - Public Involvement Plan (Appendix V) updated to present tools for keeping the public informed of FFACO corrective action and closure activities
 - Post-Closure Strategy (Appendix VII) provides the strategy for post-closure monitoring and long-term stewardship for closed CAUs
 - Appendices do not introduce new processes, but instead clarify and provide consistency for established processes

In response to Board questions, the following clarifications were provided:

- There are public reading facilities located in Las Vegas and Carson City, Nevada. There is an initiative to provide online public access to key documents created through the implementation of the FFACO.
- Appendices II, III, and IV list the Corrective Action Sites (CASs) and CAUs and are updated often to have the most recent information available regarding how many CASs are closed, how many are actively being investigated, and how many are left to be remediated. An overall update of the main body of the FFACO occurs less often with the last update in 2010. All signatories are involved with an overall update of the main body of the FFACO.

After NSSAB discussion, Chair Graham made a motion that Appendix V, *Public Involvement Plan* and the new Appendix VII, *Post-Closure Strategy* be accepted as written. The motion was seconded and passed unanimously. The Board thanked Ms. Gamero for her presentation, for answering questions, and the opportunity to review Appendices V and VII of the FFACO prior to the meeting. The NSSAB Office will draft the NSSAB recommendation letter and submit it to the EM Nevada Program for its consideration and response.

Pahute Mesa Final Well Installation Presentation #3 – Work Plan Item #7 (Ken Rehfeldt, Navarro)

- **NSSAB – Work Plan Item #7**
 - From a community perspective, the NSSAB will provide a recommendation on improvement and/or refinement for the annual update presentation for the Pahute mesa Corrective Action Units (CAUs) prior to providing to NDEP
 - NSSAB recommendation is due tonight
- **Background**
 - Beginning in 2015, UGTA provided an annual presentation to NDEP to summarize the work accomplished that year in Pahute Mesa
 - Several names over the years
 - Data Completeness Presentation during the Corrective Action Investigation (CAI) phase
 - Named Well Installation Presentation at the present time
 - Presentation content is typically technical
 - Puts the work throughout the year into context
 - Some information has previously been shared with NDEP throughout the year
 - Does not require details to be presented
 - Backup slides are often attached, but not presented
 - Dialog is encouraged via questions and discussions of work performed and outcomes
- **Agenda**
 - Overview of Pahute Mesa CAUs
 - FFACO Status of Pahute Mesa CAUs
 - Samples Collected in 2023
 - Risk Evaluation
 - Drilling Status and Well Site Preparation
 - Schedule
 - Next Steps/Summary

- **Pahute Mesa CAUs**
 - CAUs
 - Pahute Mesa CAUs
 - 82 underground tests (~10% of tests)
 - Radionuclide inventory (~60% of radionuclide inventory)
 - Public receptors are in Oasis Valley, near the community of Beatty (~25 kilometers [km])
- **FFACO UGTA Strategy – Pahute Mesa**

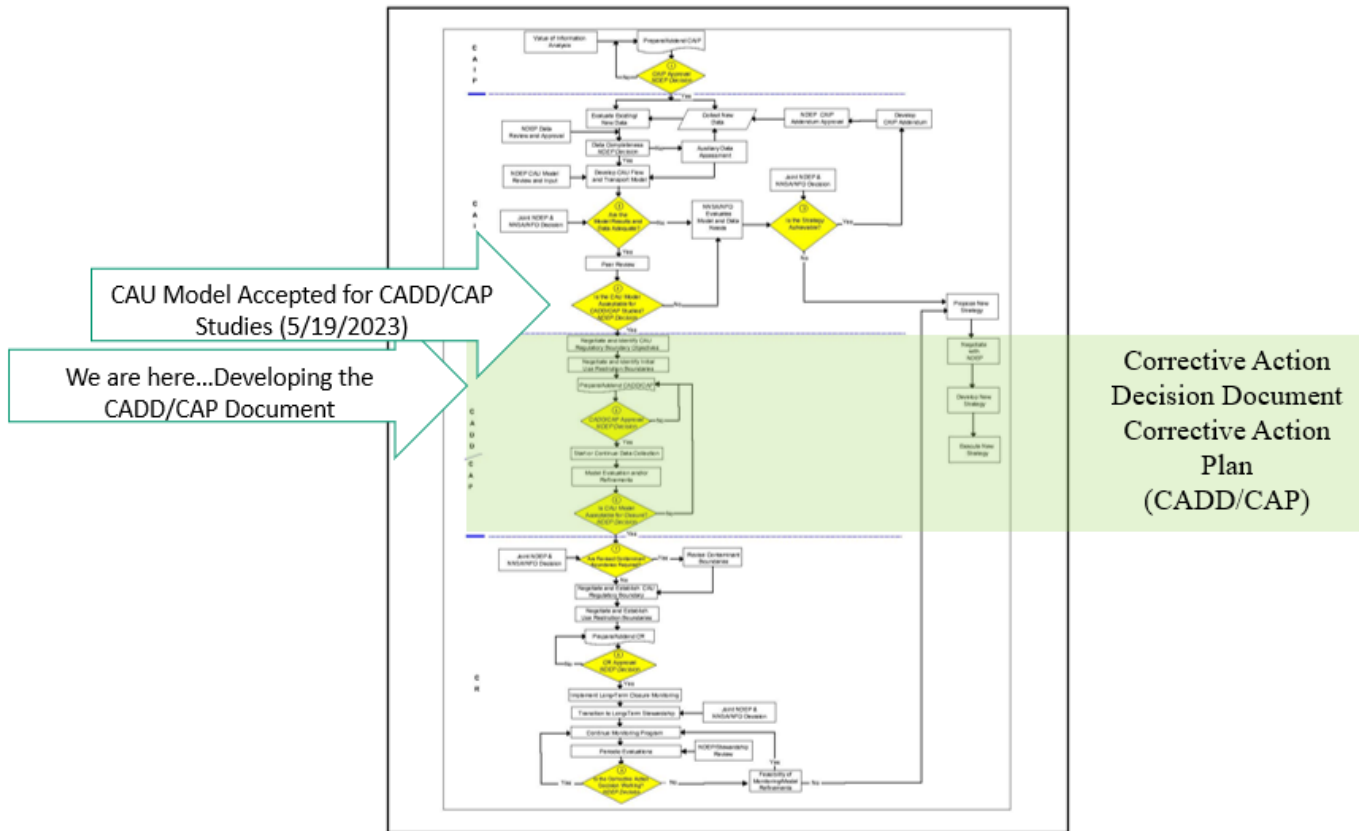

- **FFACO Strategy CADD/CAP**

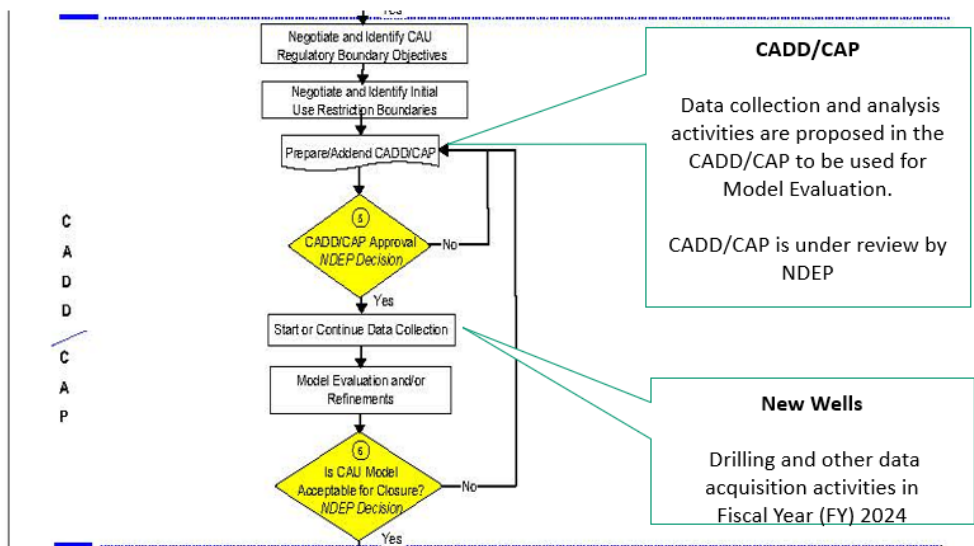

- **Pahute Mesa Sampling Locations in 2023**

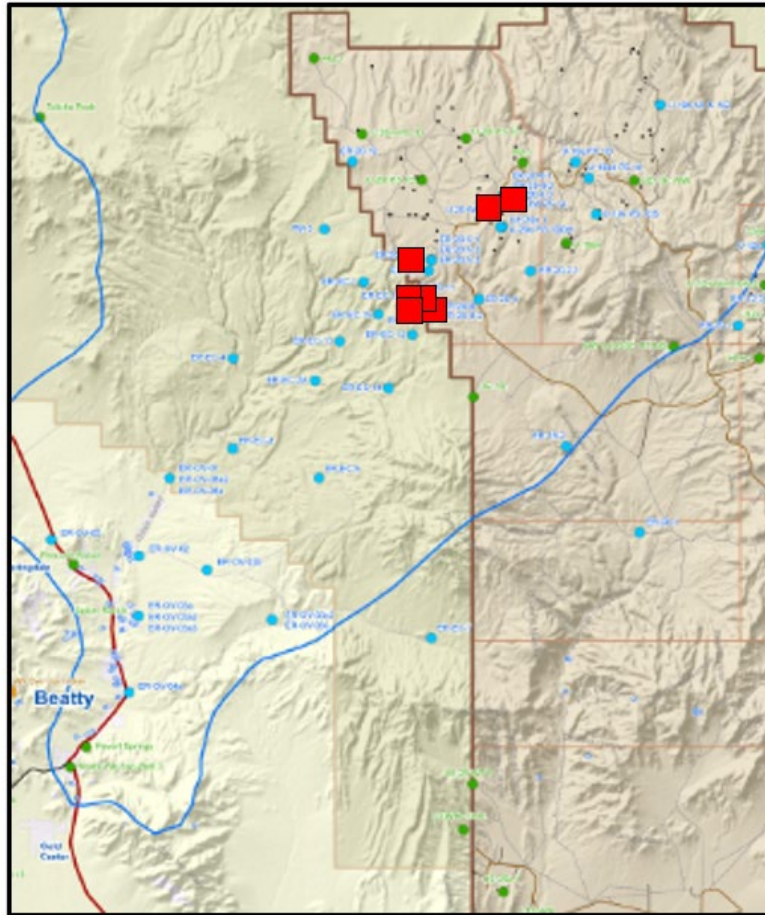

- **Pahute Mesa Sample Locations**

- 11 zones sampled in Calendar Year (CY) 2023
 - ER-20-1
 - U-20 WW
 - ER-EC-6_m2_a1, m3_a2, m4_a3
 - ER-20-8_p1, _p2
 - ER-20-8-2_p1
 - ER-20-11
 - ER-20-6-1
 - ER-20-6-3
- Special project at ER-EC-11_p3

- **Discussion of Sampling Results**

- Results from 5 zones sampled in May 2023
 - ER-20-1 – tritium detected between 5 and 6 pCi/L
 - U-20 WW – non detect (ND) for tritium – same as before – detection level 4.5 pCi/L
 - ER-EC-6_m2, _m3, _m4 – deepest to shallowest – m2 (ND), m3 (ND), m4 (9-12.6 pCi/L). In 2017, m4 was 6.7 pCi/L (Benham Aquifer): Univ of Miami, m4, 10.3-11.2 pCi/L
 - Samples from other zones in 2023 were collected in September and results are not yet available from the analytical laboratory

- Tritium Values (pCi/L)

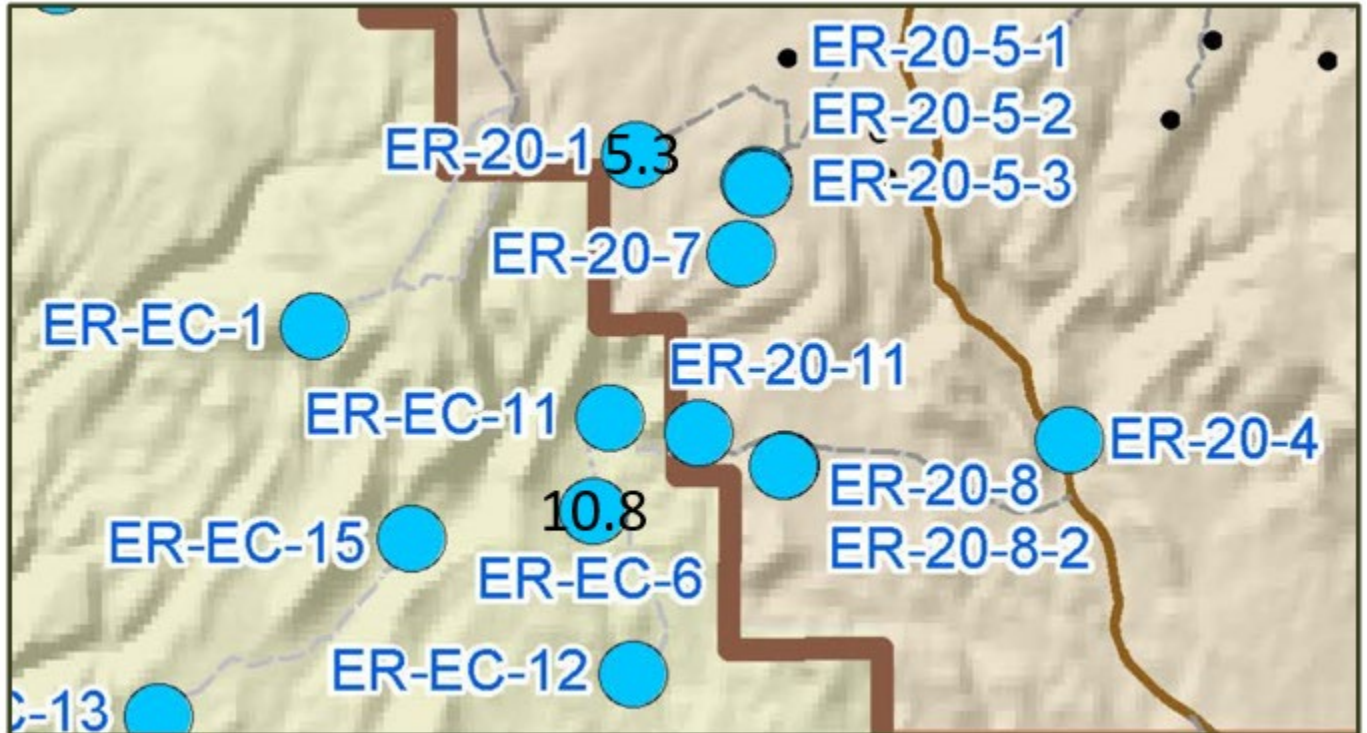

- Special Study – ER-EC-11_p3

- A special study was conducted at Well ER-EC-11_p3 to assess the change in tritium concentration measured in this piezometer between the samples collected in 2014, 2017, and 2021.

- Tritium Values (pCi/L)

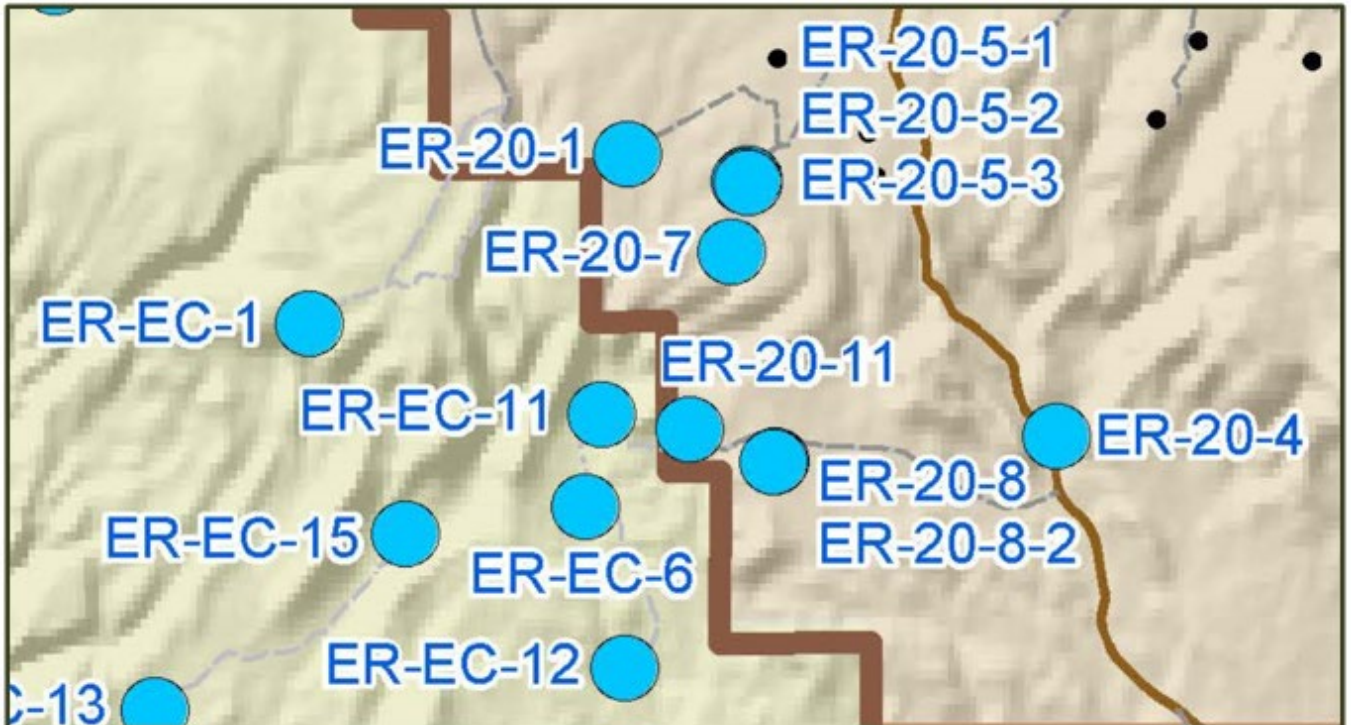

- **ER-EC-11_p3 Sampling**
 - Screen open from 2,667 to 2,991 feet (ft) below land surface
 - Open to Benham Aquifer
 - Sampling has shown increasing tritium concentrations since the well was drilled in the fall of 2009
 - Rod pump samples in 2014 were between 15,700 and 16,800 picocuries per liter (pCi/L)
 - Rod pump samples in 2017 were between 18,100 and 18,700 pCi/L
 - Baled samples in 2021 were 1,460 and 2,140 pCi/L
 - Why so low
 - Depth discrete sample did not capture the interval with high tritium concentrations
 - The higher tritium is not at the well but is drawn in by pumping
 - Sampling experiment – collect bailed samples from multiple depths, then install the rod pump and obtain a pumped sample
 - Screened interval is 313 ft long (2,678 – 2,991 ft below land surface) but the open interval is 1,365 ft long (1,665 – 3,030 ft below land surface)
 - Bail samples proposed at 2,680, 2,710, 2,800, 2,920, and 2,980 ft below land surface
 - Four discrete depths sampled with bailer
 - Then use an insert rod pump

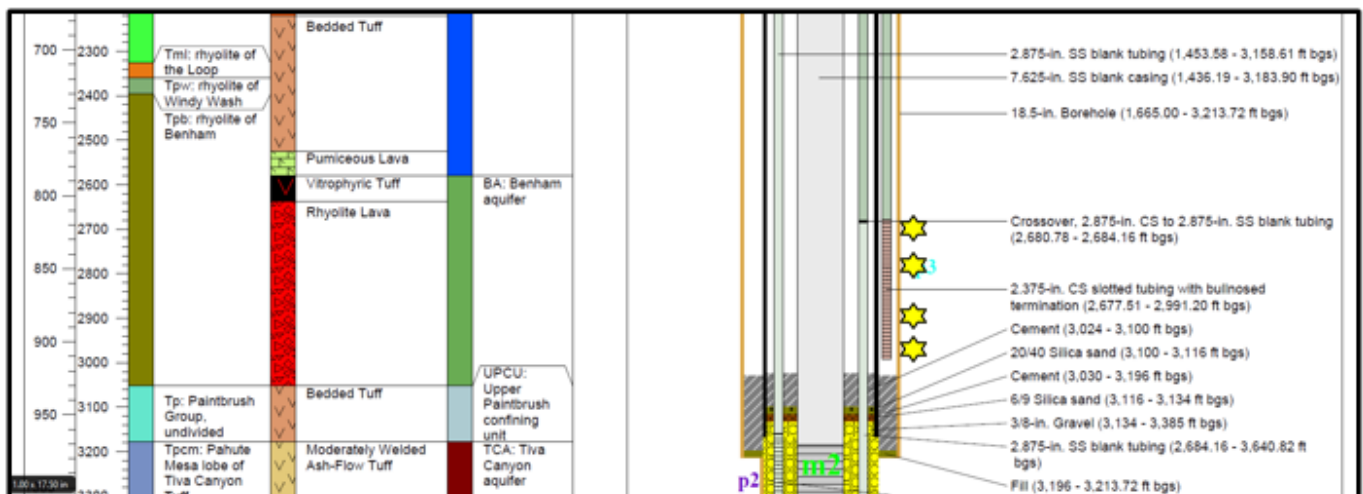

Bailed Sample Depth Below Land Surface	Tritium Value (pCi/L)
2,680	4,370 : 5,060
2,710	2,120 : 2,380
2,800	2,170 : 2,740
2,920	1,890 : 2,090
Rod Pump	TBD

- Bailer depth in 2021 was 2,750 ft below land surface
- Tritium measurements 1,460 and 2,140 pCi/L
- Contamination may come from above the screen or from near the well
- Results of the pumped sample are not yet available
- **Future Samples from ER-EC-11_p3**
 - Sampling Experiment – bailed samples are not representative at this location
 - Future samples will be collected with the rod pump
 - Rod pump has been left in the piezometer to facilitate future sample collection
 - Special study was valuable to identify the best method to sample this well

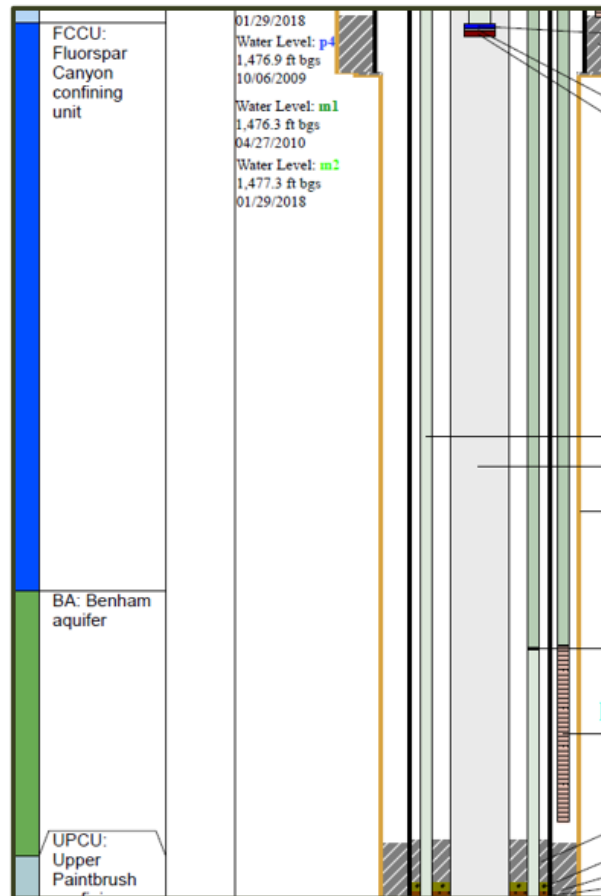

- **Risk Evaluation**
 - Follows DOE Order 458.1 Radiation Protection of the Public and the Environment
 - Used a standard of 25 millirem per year (mrem/yr) for the Maximally Exposed Individual (MEI)
 - Used multiple exposure pathways
- **Receptor Scenario – Representative Person**
 - A representative person is described as an age and gender weighted average (reference) person receiving a dose that is representative of the more highly exposed individuals in the population MEI

- **Locations of the Maximally Exposed Individual**
 - Selected six fence lines

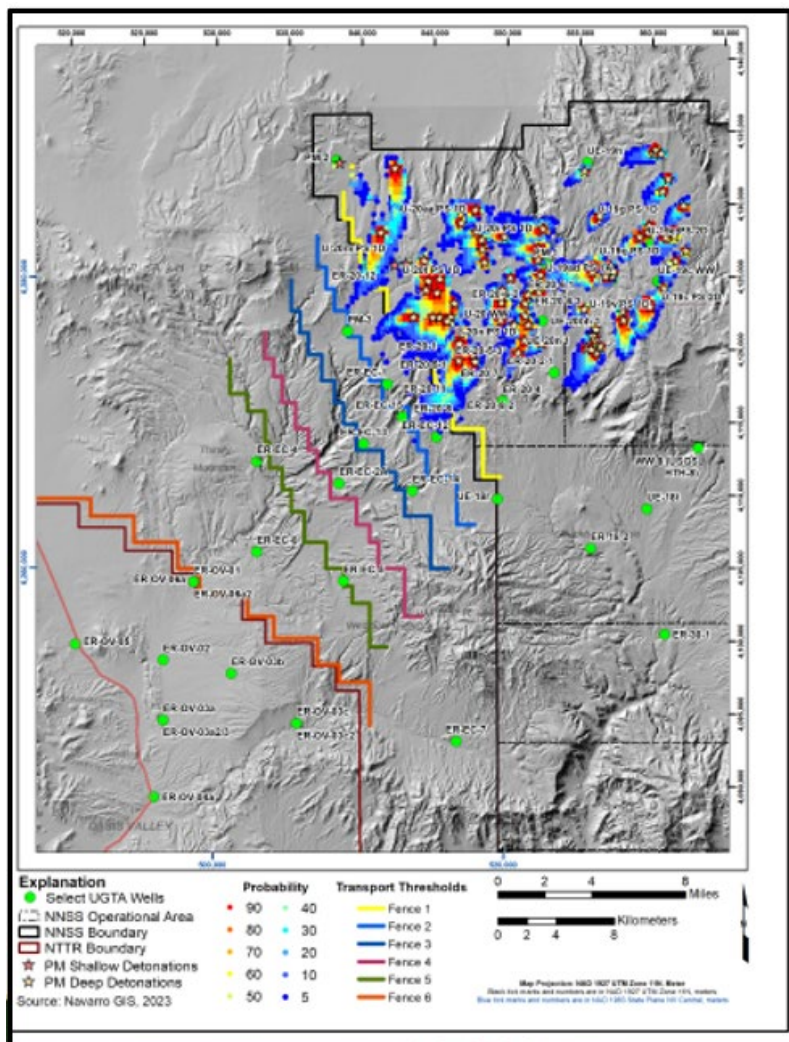

- **Specific and Total Dose (mrem/yr)**

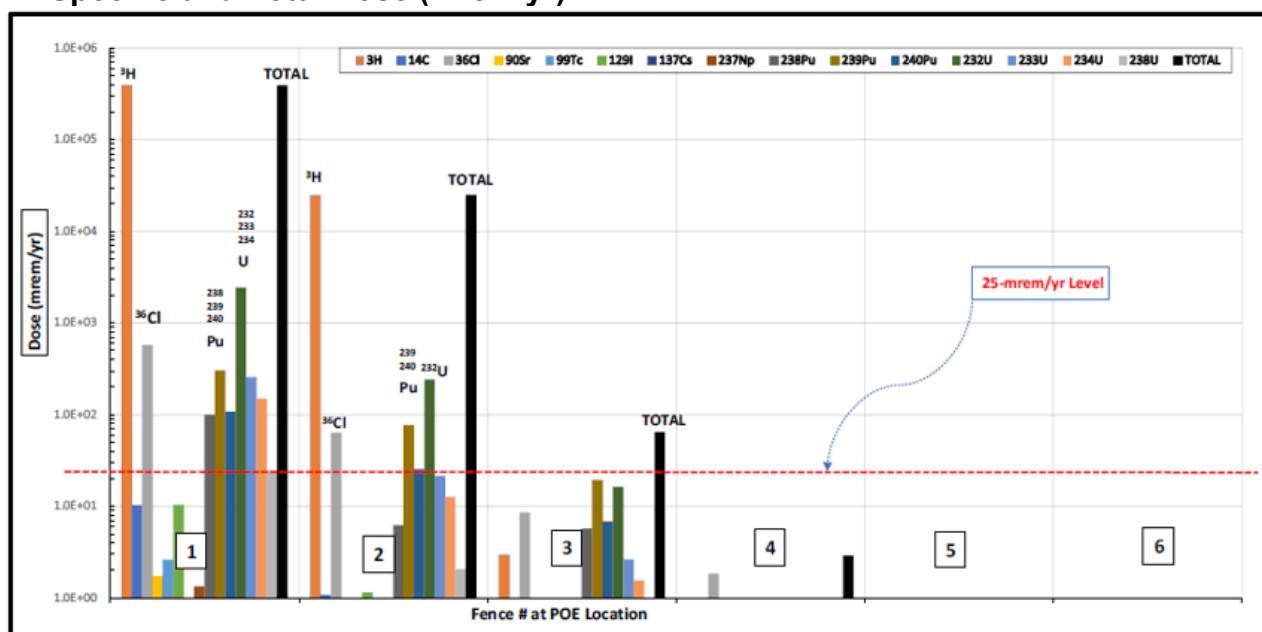

- **Comparison of the Contaminant Boundary and the Risk Evaluation**
 - The Risk Evaluation corroborates the Contaminant Boundary results that no exposures to contaminated groundwater above federal standards are forecast for groundwater users in Oasis Valley and Beatty

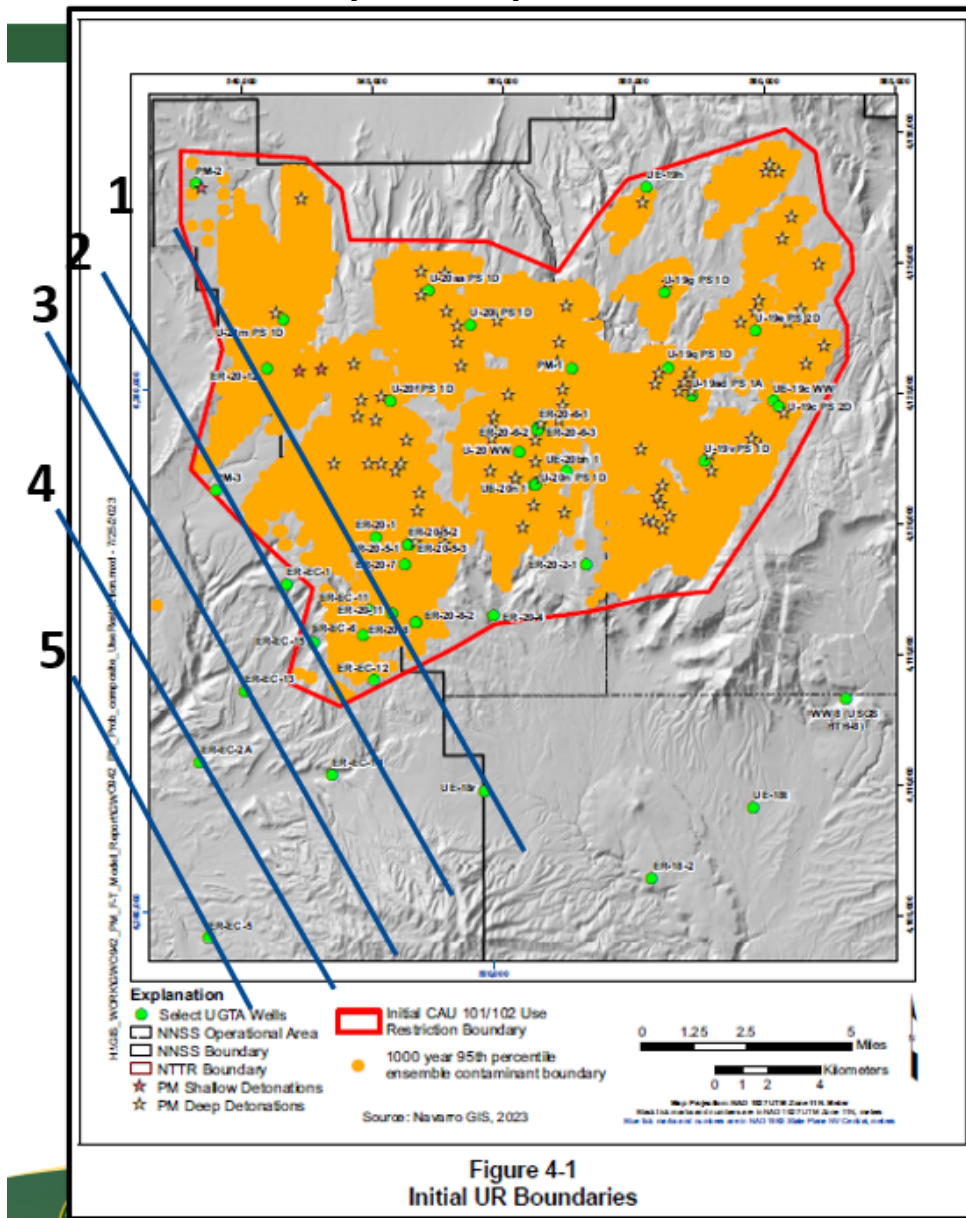
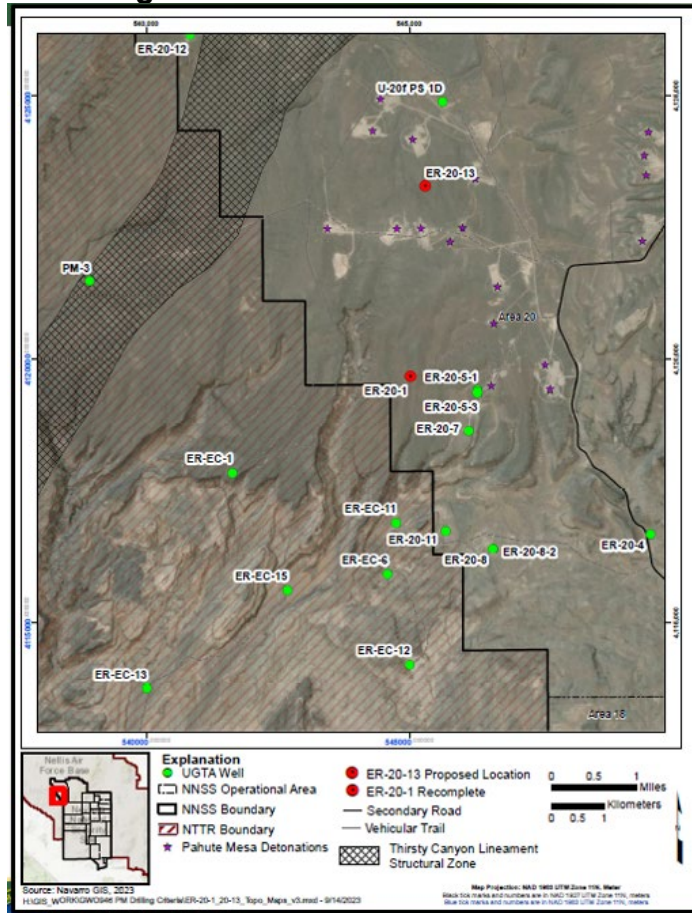

Figure 4-1
Initial UR Boundaries

- **Planned Drilling Locations**



- **Status of Drilling**

- Selected a drilling contractor – waiting for EM Consolidated Business Center (CBC) review and approval to award the contract
- Developing a detailed drilling schedule – day by day activities, contractors, subcontractors, etc.
- Preparing procurements for materials, supplies, subcontractors, etc.
- Mission Support and Test Services, LLC (MSTS) is nearly finished with road, pad, and sump construction at ER-20-1 and ER-20-13
- Drilling is planned to begin May 2024 (training, badging, etc.) with final well completion at the end of October 2024

- **Key Accomplishments in 2023**

- Pahute Mesa work under CAI stage completed in 2023; CADD/CAP stage began in 2023 and will continue for the next several years
- Groundwater sampling continues – results consistent with forecasts
- Risk Evaluation supports the contaminant boundary forecasts
- Getting ready for drilling, data collection and analysis to begin

In response to Board questions, the following clarifications were provided:

- In selecting a potential drilling contractor, EMCBC considers price reasonableness, but also that the required procedures and applicable regulations are followed so as not to put DOE at risk.

- Historically, water collected in a sump is left to evaporate, releasing hydrogen and oxygen in a water vapor, with any radionuclides concentrating down into a residue and collected on the sump's lined bottom.
- The sumps are surrounded by a fence to keep out animals and many have sand exit ramps for the animals, so they are not trapped in a sump.
- As part of DOE Order 458.1 *Radiation Protection of the Public and the Environment*, the management and operating contractor is responsible for conducting an annual analysis of the animals and birds on the NNSS. This is conducted by an opportunistic sampling of birds and animals, i.e., deer accidentally hit by a car. With this information, a potential dose to the public from the consumption of game animals is determined and published annually in the NNSS Environmental Report. The report is written to inform the public, regulators, employees, and other stakeholders of the performance of the NNSS environmental program and the 2022 edition can be accessed [here](#). This report also contains groundwater sampling results.
- An explanation of the well naming convention: ER-20-XX - ER stands for Environmental Restoration, 20 means that the well is located in Area 20 on the NNSS. Another example, ER-EC-XX, the well is located on the Nevada Test and Training Range and was drilled when it was an electronic combat (EC) range.
- Once a geographic unit is found to contain contamination during the drilling of a well, the unit must be cased off and isolated before drilling can continue.
- During the closure stages of Pahute Mesa, the EM Nevada Program will have discussions with NDEP for what locations are going to be sampled, how often, and what radionuclides will be analyzed.
- The Benham Aquifer was named after a particular nuclear test. There is a wide range of naming conventions for the underground geographic units and many times was at the discretion of the geologist conducting the initial mapping and understanding of the various units.

Chair Graham led Board discussion on work plan item #7 with potential recommendations provided by members during the meeting on improvement and/or refinement for the annual update presentation for the Pahute Mesa CAUs prior to providing to NDEP:

- Potential recommendation #1: Chair Graham brought forward for discussion that map keys be added to pages 10, 13, and 15, and kilometers/miles conflict be resolved on page 7.
- Potential recommendation #2: Member Elgort brought forward for discussion that naming conventions between wells be explained.
- Potential recommendation #3: Member Elgort brought forward for discussion that physical blocks between sampling zones be explained.

Member Trainor made a motion that #1 and #3 listed above be submitted to the EM Nevada Program as recommendations. The motion was seconded. After Board discussion, the motion passed unanimously.

Member Elgort made a motion that #2 listed above be submitted to the EM Nevada Program as a recommendation. The motion was seconded. After Board discussion, the motion passed unanimously.

Chair Graham thanked Mr. Rehfeldt for his presentation and answering the Board's questions. He thanked members for their interest and providing recommendations on this work plan item. The NSSAB Office will draft the NSSAB recommendation letter and submit it to the EM Nevada Program for its consideration and response.

Meeting Wrap-Up and Adjournment

Upcoming calendar of events:

- NSSAB Full Board meeting – Valley Electric Association's Valley Conference Center, Pahrump, NV at 4 p.m. – January 17, 2024

Member Trainor made a motion to adjourn the meeting. The motion was seconded and passed unanimously. The meeting was adjourned at 8:02 p.m.